

PLAN VIEW

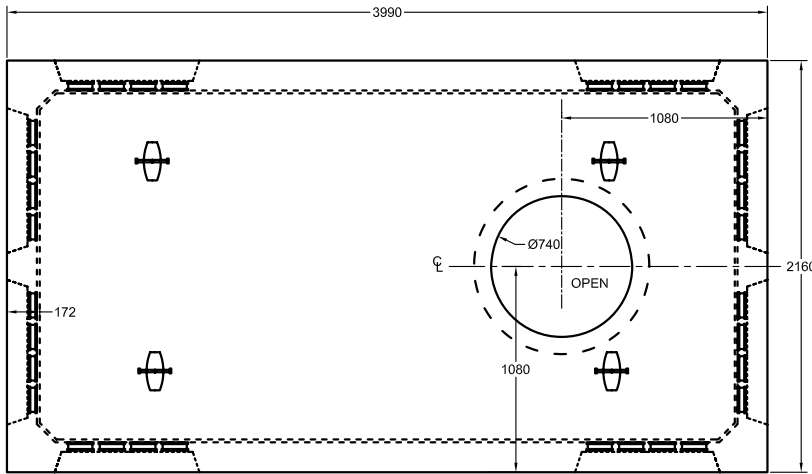

NOTES:

- ▣ 96 - 4"Ø Polylock Pipe Seals
- ▣ Concrete Strength: 30 MPa [min.] Air Entrained [5 - 8%]
- ▣ Wall Thickness: 150 mm [min.]
- ▣ 4 - Utility Anchors Outside for Lifting (no sp. rigging req'd)
- ▣ 4 - Utility Anchors Inside [Used as Pulling Eyes]
- ▣ 1 - 740Ø mm Manhole Opening at Top [Off-set]
- ▣ Heavily Reinforced with 10M & 15M Bars
- ▣ 24 - 13mm Racking Inserts on Inside Walls
- ▣ Total Weight: 7,433 kg [16,352 lbs.]

SIDE PROFILE VIEW

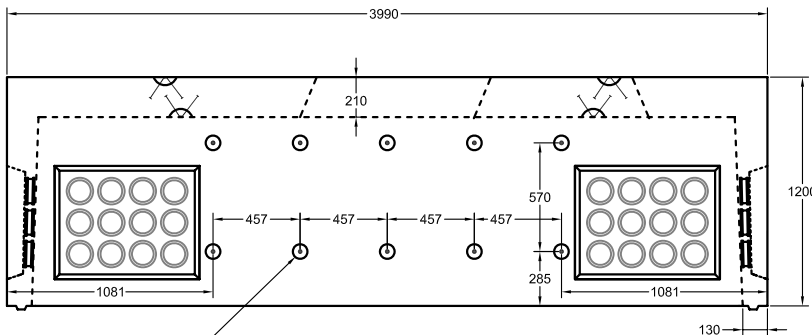

13mmØ RACKING INSERTS
10 ON EACH LONG WALL
AND 2 ON EACH SHORT WALL

END PROFILE VIEW

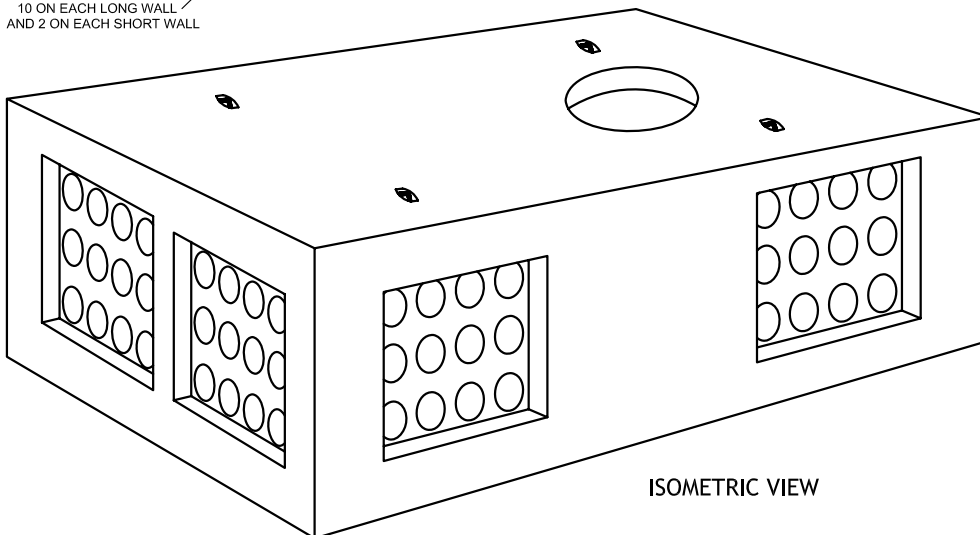
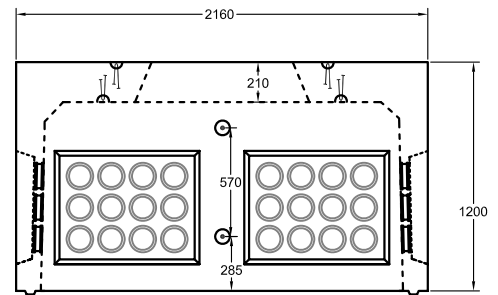

ISOMETRIC VIEW

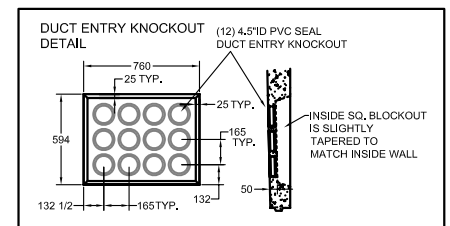

Hy-Grade Precast Concrete
2411 First Street Louth
St. Catharines, Ontario, L2R 6P7
Tel: 1-800-229-8568
Fax: 905-684-8560



Hy-Grade Precast Concrete Products, Inc.
PO Box 148
South Byron, New York, USA 14557
Tel: 1-877-897-2730
Fax: 585-548-2731