

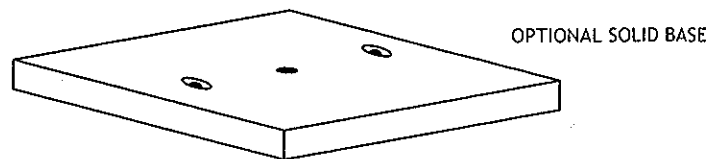

**HY-GRADE**  
PRECAST CONCRETE

**TRANSFORMER PAD**  
**TP-103D w/ DUCT BANK TERMINATORS**  
**FOR UP TO 1200 KVA TRANSFORMER**

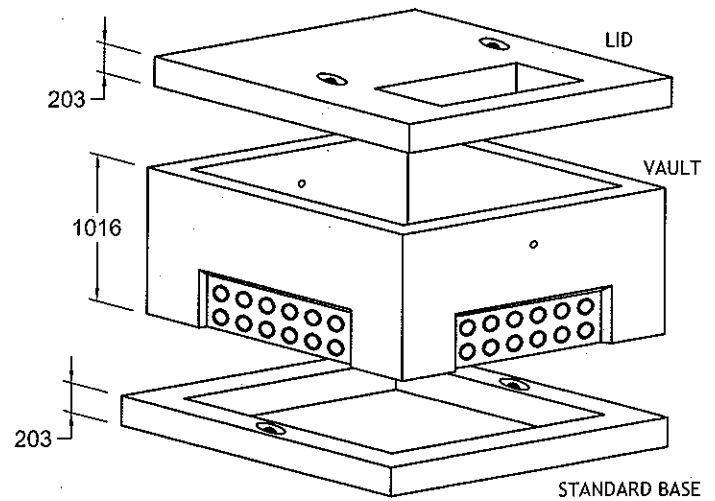
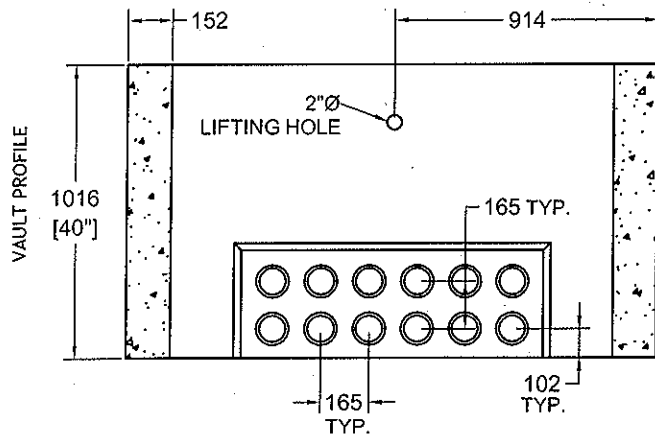
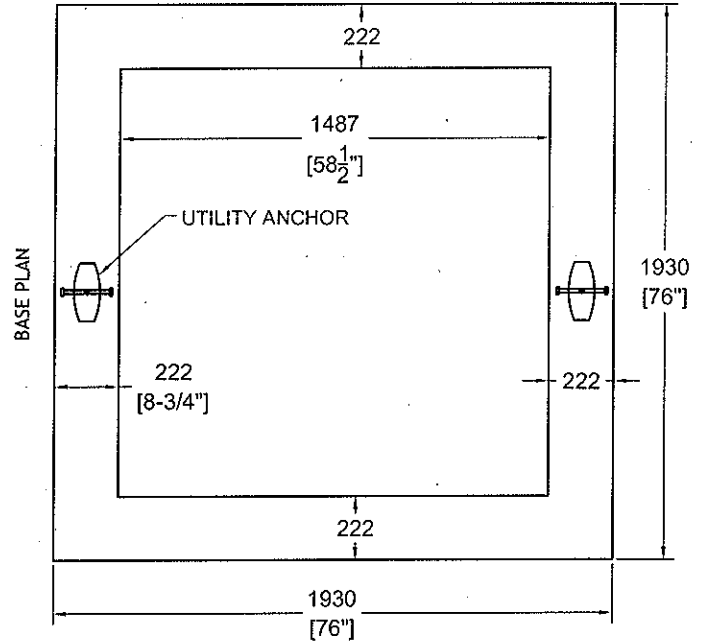
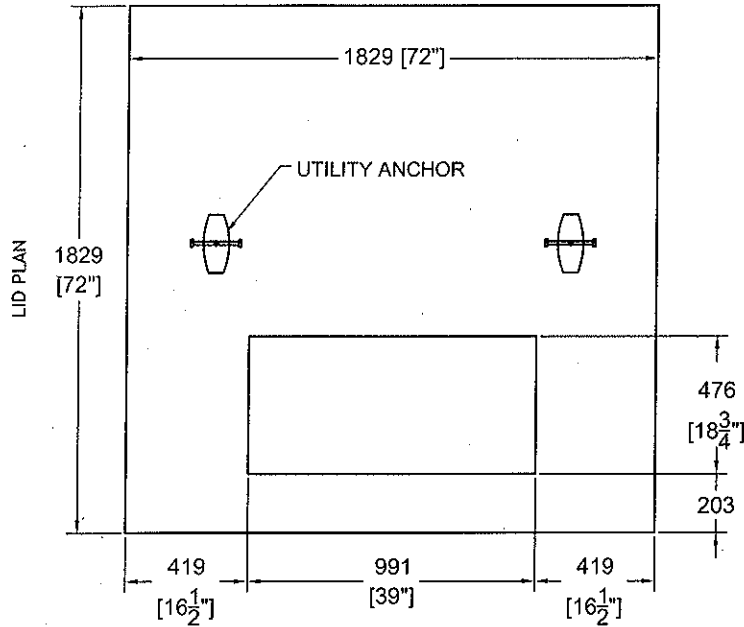

**NOTES:**

- ▣ 48 - 4"Ø Polylock Pipe Seals
- ▣ Concrete Strength: 30 MPa [min.] Air Entrained [5 - 8%]
- ▣ Wall Thickness: 152mm [6"]
- ▣ BASE & LID Thickness: 203mm [8"]
- ▣ Reinforcement: 10M Rebar & 4x4x4/4 WWF
- ▣ LID Weight: 1,400 kg [3,085 lbs.]
- ▣ VAULT Weight: 2,145 kg [4,725 lbs.]
- ▣ BASE Weight: 745 kg [1,635 lbs.]
- ▣ OPTIONAL SOLID BASE Weight: 1 821 kg [4 015 lbs.]

Hy-Grade Precast Concrete  
2411 First Street Louth  
St. Catharines, Ontario, L2R 6P7  
Tel: 1-800-229-8568  
Fax: 905-684-8560



[www.hygradeprecast.com](http://www.hygradeprecast.com)

Hy-Grade Precast Concrete Products, Inc.  
PO Box 148  
Byron, New York, USA 14557  
Tel: 1-877-897-2730  
Fax: 585-548-2731