

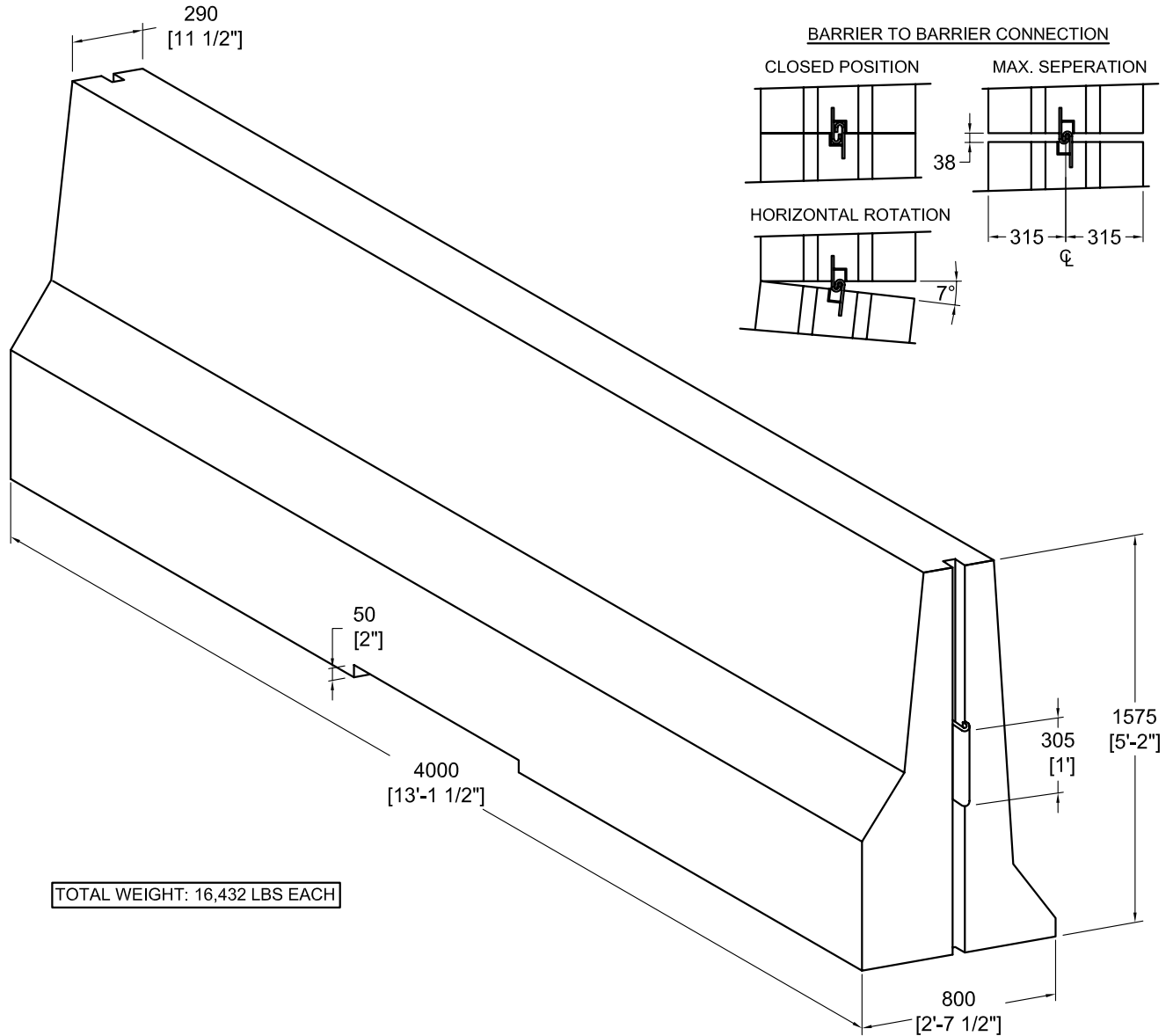

HY-GRADE
PRECAST CONCRETE

**ASYMETRIC - TYPE TW-1
PRECAST CONCRETE BARRIER**



Manufactured to meet your needs...

Designed for permanent or temporary use
 Long Lasting...Low life Cycle Costs
 Durable Precast will not Rust, Rot or Burn
 Maintenance Free
 Uniformity in Appearance, Weight, Strength and Colour
 Safe, Quick and Easy Installation by Your Labour Force

Design meets MTOD - 911 specifications

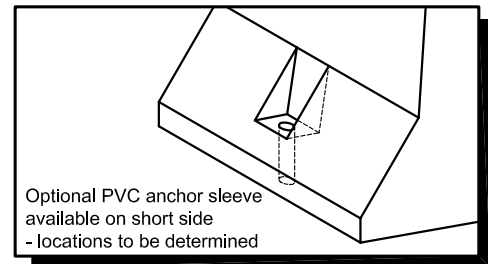

Hy-Grade Precast Concrete
 2411 First Street Louth
 St. Catharines, Ontario, L2R 6P7
 Tel: 1-800-229-8568
 Fax: 905-684-8560



www.hygradeprecast.com

Hy-Grade Precast Concrete Products, Inc.
 PO Box 148
 Byron, New York, USA 14557
 Tel: 1-877-897-2730
 Fax: 585-548-2731